

# SUPPLEMENT TO INSTRUCTION MANUAL

P/N 238-51012-00

(Replaces pg. 2 in instruction manual.)

## CONGRATULATIONS!

You have just purchased one of the finest water heaters on the market today!

This installation, operation and instruction manual will explain in detail the installation and maintenance of your new Flammable Vapor Ignition Resistant Gas Water Heater. We strongly recommend that you contact a plumbing professional for the installation of this water heater.

We require that you carefully read this manual, as well as the enclosed warranty, and refer to it when questions arise. If you have any specific questions concerning your warranty, please consult the plumbing professional from whom your water heater was purchased. For your records we recommend that you write the model, serial number and installation date of your water heater in the maintenance section in the back of this manual.

This manual should be kept with the water heater.

### Special Flammable Vapor Ignition Resistant System:

This water heater is equipped with a Flammable Vapor Ignition Resistant System. In the event of improper usage or storage of gasoline or other flammable materials in the location where the water heater is installed, the technology will resist ignition of the flammable vapors outside the confines of the water heater.

The Flammable Vapor Ignition Resistant System features:

- Advanced Flame Arrestor Design.
- Intelligent Diagnostic Control to prevent burner/pilot operation with restricted airflow.
- Spark Igniter
- Sight Window to observe operation of pilot and burner.

**FOR YOUR SAFETY:** Activation of the Flammable Vapor Ignition Resistant System occurs when flammable vapors are drawn into the water heater and are combusted. If flammable vapors are detected:

- Do not try to light any appliance.
- Do not touch any electrical switch; Do not use any phone in your building.
- Leave the premises and immediately call the fire department from a neighbor's phone. Follow the fire department's instructions.

Once the flammable vapor has been evacuated, contact your plumbing professional or the manufacturer for further instructions. Replacement of a Flammable Vapor Ignition Resistant System equipped water heater due to a flammable vapor shutdown is not covered under the terms of the limited warranty.

## MINIMUM CLEARANCES

(Replaces pg. 9 in instruction manual.)

### ⚠ WARNING

Failure to adhere to these installation and operating instructions may create a hazard to life and property and will nullify the warranty.

### ⚠ CAUTION

Do not solder plumbing joints directly above the flue. Solder may fall down the flue and cause damage to combustion components.

This installation shall allow access to the front of the water heater and adequate clearance shall be provided for servicing and operating this water heater. The water heater may be installed on either a combustible or non-combustible floor. If the water heater is to be installed directly on carpeting, it shall be installed on top of a metal or wood panel (or equivalent) extending beyond the full width and depth of the appliance by at least three (3) inches (7.6 cm) in any direction or, if the appliance is to be installed in an alcove or closet, the entire floor shall be covered by the panel. **If the rating plate or the label on the front of the water heater specifies minimum clearances less than those listed in the below table, the water heater may be installed in accordance with the minimum clearances listed on the rating plate or the label on the front of the water heater.**

If it is necessary to install this water heater in an alcove, use the clearances listed in Figure 1.

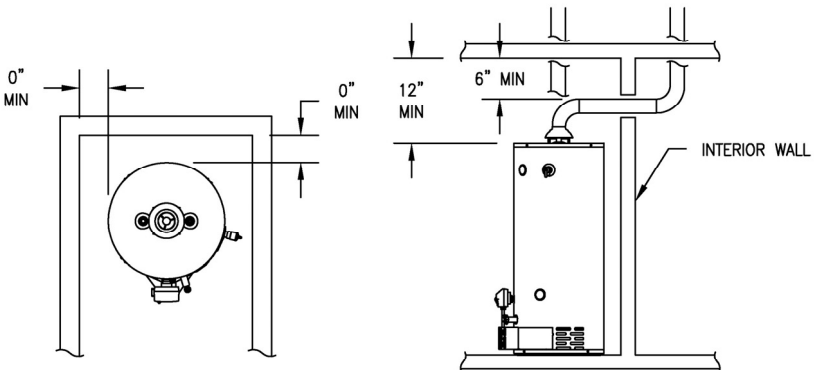

Figure 1

# Lighting and Shutdown Instructions (Replaces pg. 19 in instruction manual.)

## FOR YOUR SAFETY READ BEFORE LIGHTING

**WARNING:** If you do not follow these instructions exactly, a fire or explosion may result causing property damage, personal injury or loss of life.

A. This appliance is equipped with an ignition device which automatically lights the pilot. Do not try to light the pilot by hand.

B. **BEFORE OPERATING** smell all around the appliance area for gas. Be sure to smell next to the floor because some gas is heavier than air and will settle to the floor.

### WHAT TO DO IF YOU SMELL GAS

- Do not try to light any appliance.
- Do not touch any electrical switch; do not use any phone in your building.
- Immediately call your gas supplier from a neighbor's phone. Follow the gas supplier's instructions.

• If you cannot reach your gas supplier, call the fire department.

C. Use only your hand to slide the gas control switch. Never use tools. If the switch cannot be moved by hand, do not try to repair it, call a service technician. Force or attempted repair may result in a fire or explosion.

D. Do not use this appliance if any part has been under water. Immediately call a qualified service technician to inspect the appliance and to replace any part of the control system and any gas control which has been under water.

## OPERATING INSTRUCTIONS

1. STOP! Read the safety information above.
2. Turn off all electric power to the appliance.
3. Set the thermostat to lowest setting.
4. This appliance is equipped with an ignition device which automatically lights the pilot. Do not try to light the pilot by hand.

GAS CONTROL KNOB SHOWN  
IN THE "OFF" POSITION

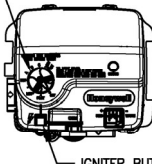

5. Slide the switch on the right side of the gas valve down to the "OFF" position

6. Wait five (5) minutes to clear out any gas, then smell for gas, including near the floor. If you smell gas, STOP! Follow "B" in the safety information at left on this label. If you don't smell gas, go to the next step.

7. Slide the switch on the right side of the gas valve up to the "ON" position.

8. Set thermostat to desired setting.

9. Turn on all electric power to the appliance.

10. If the appliance will not operate, follow the instructions "To Turn Off Gas To Appliance" and call your service technician or gas supplier.

## TO TURN OFF GAS TO APPLIANCE

1. Turn off all electric power to the appliance if service is to be performed.
2. Set the thermostat to the lowest setting.

3. Slide the switch on the right side of the gas valve down to the "OFF" position.

## THERMOSTAT ADJUSTMENT (Replaces pg. 21 in instruction manual.)

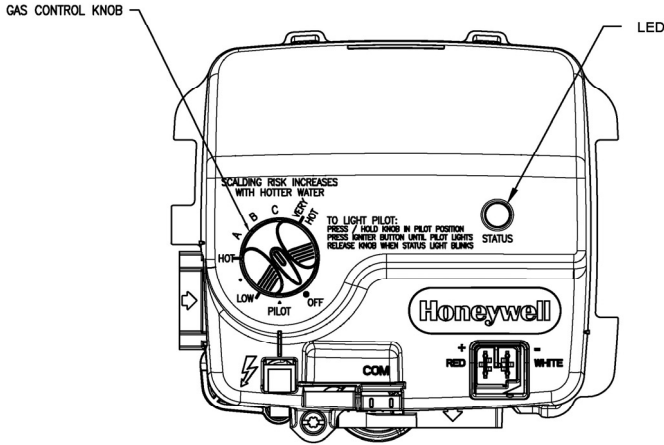

**NOTE:** Taupe / Silver faceplate is approximately 160°F maximum set point, Dark (Battleship) Grey faceplate is approximately 180°F maximum set point.

**Figure 2**

### **⚠ DANGER**

Hotter water increases the risk of scald injury. Scalding may occur within five (5) seconds at a temperature setting of 140°F (60°C). To protect against hot water injury, install an ASSE approved mixing valve in the water system. This valve will reduce point of discharge temperature by mixing cold and hot water in branch water lines. A licensed plumbing professional or local plumbing authority should be consulted.

**Note:** This water heater is equipped with an energy cut out device to prevent overheating. Should overheating occur or the gas supply fail to shut off, turn off the manual gas control valve to the appliance and call a qualified service technician.

**Note:** Whenever the water heater is filled with cold water, condensate will form on the cool tank surface and drops of water will fall on the hot burner and combustion chamber surfaces producing a “sizzling” noise. Condensation is normal and does not indicate a leak. It will disappear when the tank becomes heated.

**BURNER FLAME CHECK**  
**(Replaces pg. 22 in instruction manual.)**

These models are equipped with self adjusting air mixture and do not have an adjustable air shutter. At periodic intervals, a visual check of the main burner and pilot flames should be made to determine if they are burning properly. The main burner flame should light smoothly from the pilot. The burner flame should be soft and undefined. After five minutes of burner operation the burner face should be glowing orange and emitting an orange flame.

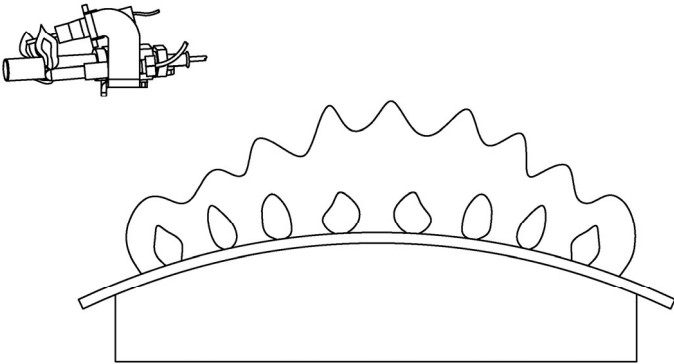

**Figure 3**

# INSTALLATION FOR POTABLE WATER

(Replaces pg. 28 in instruction manual.)

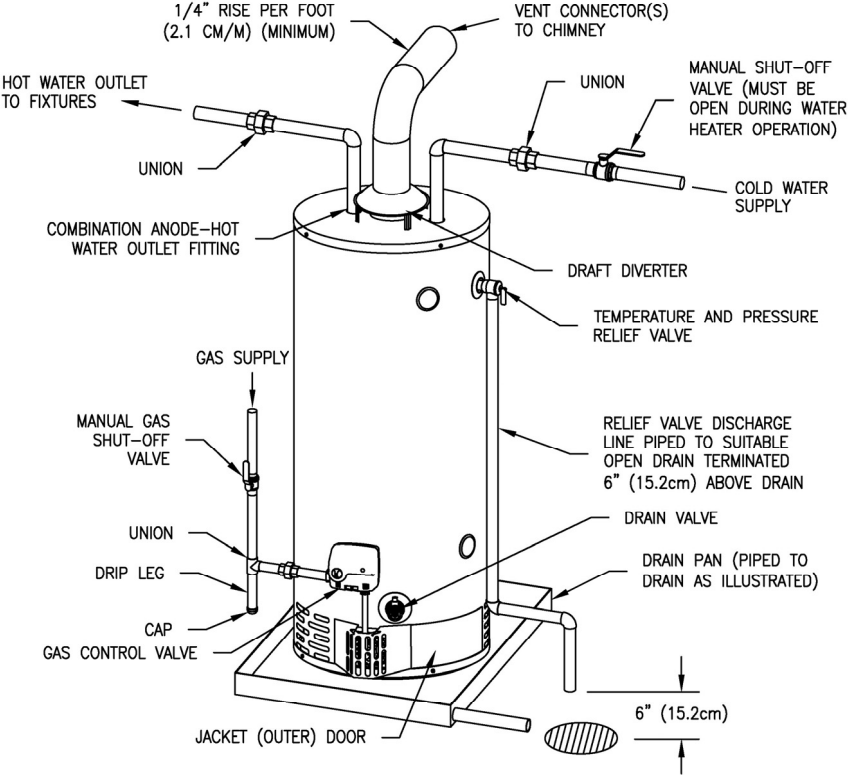

**Figure 4**

**PARTS LIST DRAWING**  
(Replaces pg. 29 in instruction manual.)

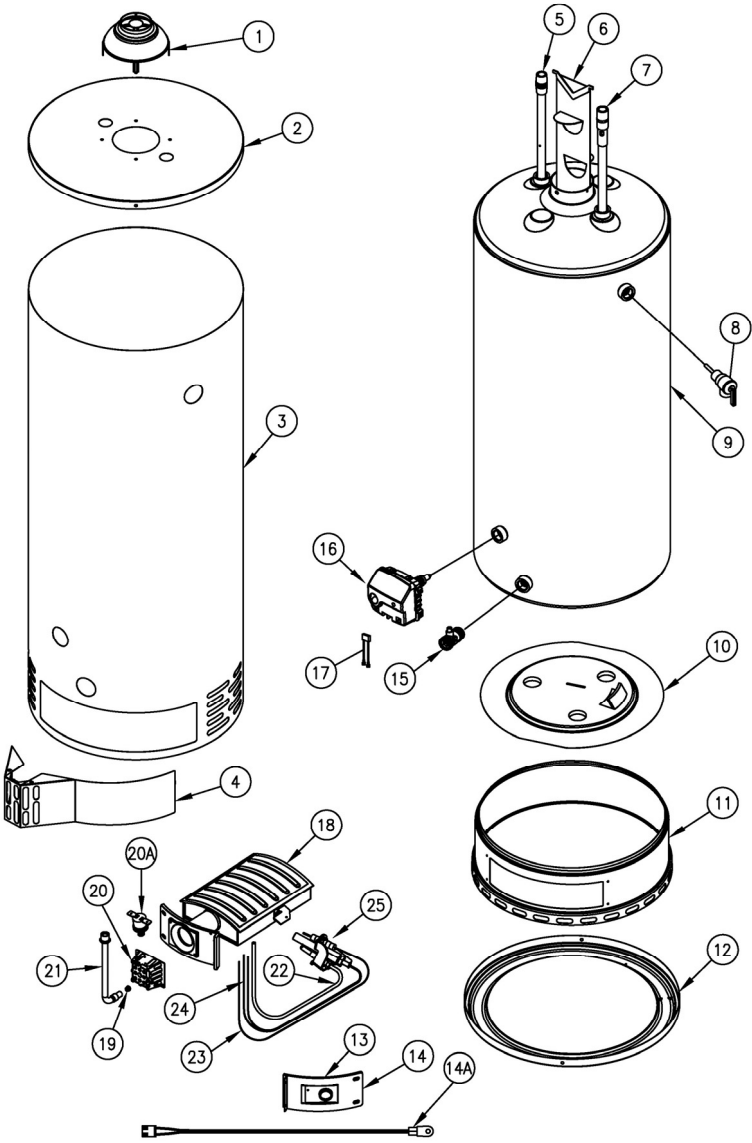

**Figure 5**

## PARTS LIST

(Replaces pg. 30 in instruction manual.)

PART NAME AND DESCRIPTION	
1. Draft Diverter	14a. Resistance Temperature Detector
2. Jacket Head Pan	15. Drain Valve
3. Jacket	16. Gas Valve
4. Outer Door	17. Wire Harness
5. Magnesium Anode–Hot Water Outlet	18. Radiant Burner
6. Flue Baffle Assembly	19. Orifice
7. Dip Tube–Cold Water Inlet	20. Manifold Mount
8. Temperature and Pressure Relief Valve	20a. High Temperature Limit Switch
9. Glass Lined Tank	21. Gas Feedline to Burner
10. Secondary-Air Restrictor Plate	22. Gas Feedline to Pilot
11. Combustion Chamber Assembly	23. Spark Igniter
12. Jacket Base Pan	24. Thermopile
13. Inner Door Gasket	25. Pilot Assembly
14. Inner Door Assembly	



**THE FOLLOWING INSTRUCTIONS ARE FOR INSTALLATION OF:  
GAS WATER HEATERS SUITABLE FOR WATER (POTABLE)  
HEATING AND SPACE HEATING  
(Replaces pg. 31 in instruction manual.)**

All piping components connected to this water heater for space heating applications must be suitable for use with potable water. In Massachusetts, space heating piping length **must not** exceed 50 feet.

1. Toxic chemicals, such as those used for boiler treatment, **must not** be introduced into potable water used for space heating.
2. This water heater **must not** be connected to an existing heating system or component(s) previously used with a non-potable water heating appliance.
3. When the system requires water for space heating at temperatures higher than required for other uses, a means such as an ASSE approved mixing valve shall be installed to temper the water for those uses in order to reduce scald hazard potential.

Please refer to figure 6 and figure 7 for suggested piping arrangements.

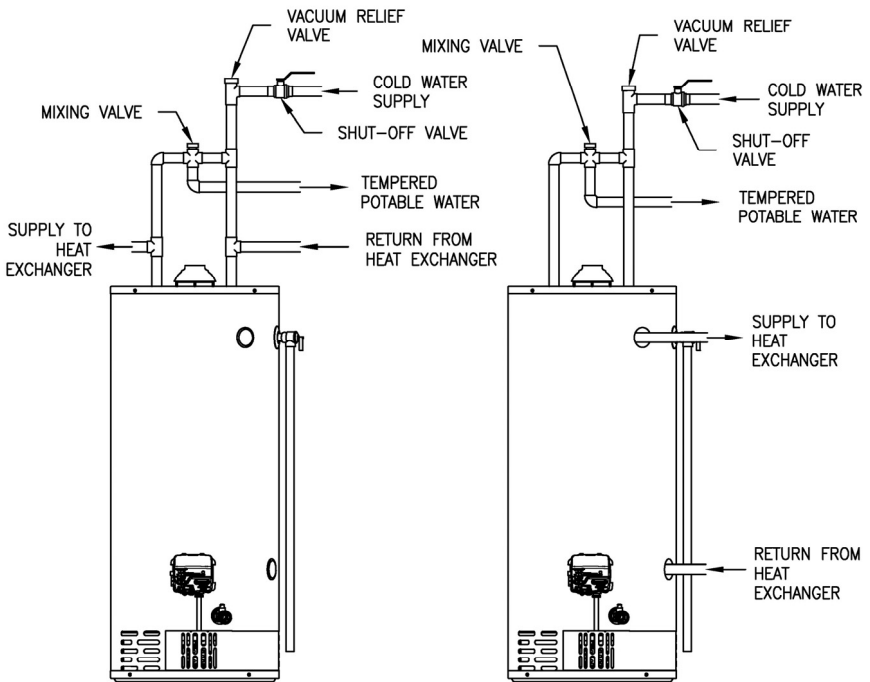

**Figure 6**

**Figure 7**

# TROUBLESHOOTING

(In addition to instruction manual.)

LED Status	Control Status	Probable Cause
None (LED not on or flashing)	Millivolt power is not present. Light Pilot	Gas valve is not powered. Light pilot.
One flash and three second pause.	If set point knob is in "PILOT" position then pilot flame is detected. Turn set point knob to desired setting. If set point knob is at the desired setting the thermostat is satisfied (no faults).	Gas valve is powered and waiting for the set point knob to be turned to a water temperature setting. If the set point knob is already at the desired setting, temperature demand is satisfied (no call for heat).
LED strobe (two quick flashes) and three second pause.	Thermostat calling for heat (no faults).	Tank temperature below setpoint of thermostat.
LED on continuously.	Set point knob has been recently turned to the "OFF" position. Wait until LED goes out before attempting to relight.	Set point knob was turned to "OFF" position.
Two flashes and three second pause.	Weak pilot flame detected. System will reset when pilot flame is sufficient.	<ol style="list-style-type: none"> <li>1. Unstable pilot.</li> <li>2. Pilot tube block or restricted.</li> </ol>
Three flashes and three second pause.	Insufficient water heating. System will reset.	<ol style="list-style-type: none"> <li>1. Thermowell sensor and chamber temperature sensor out of calibration.</li> <li>2. Possible short.</li> </ol>
Four flashes and three second pause.	Excessive tank temperature. System must be reset.	<ol style="list-style-type: none"> <li>1. Thermowell sensor out of calibration.</li> <li>2. Faulty gas valve.</li> </ol>

**Troubleshooting continued-**  
**(In addition to instruction manual.)**

LED Status	Control Status	Probable Cause
Five flashes and three second pause.	Thermostat well fault.	<ol style="list-style-type: none"> <li>1. Damage to the thermowell wire.</li> <li>2. Thermowell sensor resistance out of range.</li> <li>3. Replace thermowell.</li> <li>4. Verify control is not wet or physically damaged.</li> <li>5. Turn set point knob to "OFF" position. Turn set point knob to "PILOT" position and light pilot.</li> <li>6. Replace gas valve if five flash error persists.</li> </ol>
Six flashes and three second pause.	Chamber temperature sensor out of specification. Possible short.	<ol style="list-style-type: none"> <li>1. Chamber temperature sensor out of calibration.</li> <li>2. Possible short.</li> </ol>
Seven flashes and three second pause.	Gas valve electronic fault detected.	<ol style="list-style-type: none"> <li>1. Verify control is not wet or physically damaged.</li> <li>2. Turn set point knob to "OFF" position. Turn set point knob to "PILOT" position and light pilot.</li> <li>3. Replace gas valve if seven flash error persists.</li> </ol>
Eight flashes and three second pause.	False pilot flame present.	Pilot valve stuck in open position.
Ten flashes and three second pause.	Insufficient combustion air detected. Reset system.	Insufficient combustion air.

# Notes